



Fitting Instruction

TOWBAR KA44U
For Kia Optima SW 2016 -

MATERIALS

- A 1 Main Crossbar
- C 1 R/H Sidearm.
- D 1 L/H Sidearm.
- E 2 Spacers.
- F 4 M12 x 35 x 1.75 Bolts and Nyloc nuts.
- G 4 M12 x 45 x **1.25 (FINE PITCH)** Bolts, Flat washers and Lock washers.

Note: This towbar must be used with either a Witter Towball (part number Z11) or Class A50-1 or A50-X towball, which dimensionally conforms to A50-1 with a 'D' and 'S' value greater than or equal to that of the towbar.

FITTING

1. Remove bumper, undo wheel arch fixings and fixings along bumper lower edge, remove light clusters and fixings underneath. **Note:** there may be plastic fixings within bumper which can be released from under vehicle, one either side on crash beam.
2. Lower exhaust silencer on L/H side (either side on GT line) and remove exhaust heat shield/s allowing access to mounting holes for towing bracket.
3. using **fine pitch** fixings "G" loosely attach parts "E", "C" and "D" then using fixings "F" attach crossbar "A".
4. Cut heat shield or shields if twin exhaust model (see diagram below, mirror for twin exhaust model if reqd).
5. Ensure all fixings have been fully tightened to correct torque settings.
6. Re-fit bumper with required cut (larger cut required if retractable electrical plate is used)
7. Fit chosen neck option.

Recommended torque settings: Grade 8.8 bolts: M8 - 24Nm, M10 - 52 Nm, M12 - 80 Nm, M14 - 130 Nm, M16 - 200 Nm
Grade 10.9: M12 - 120Nm, M10 - 70Nm M8- 35Nm

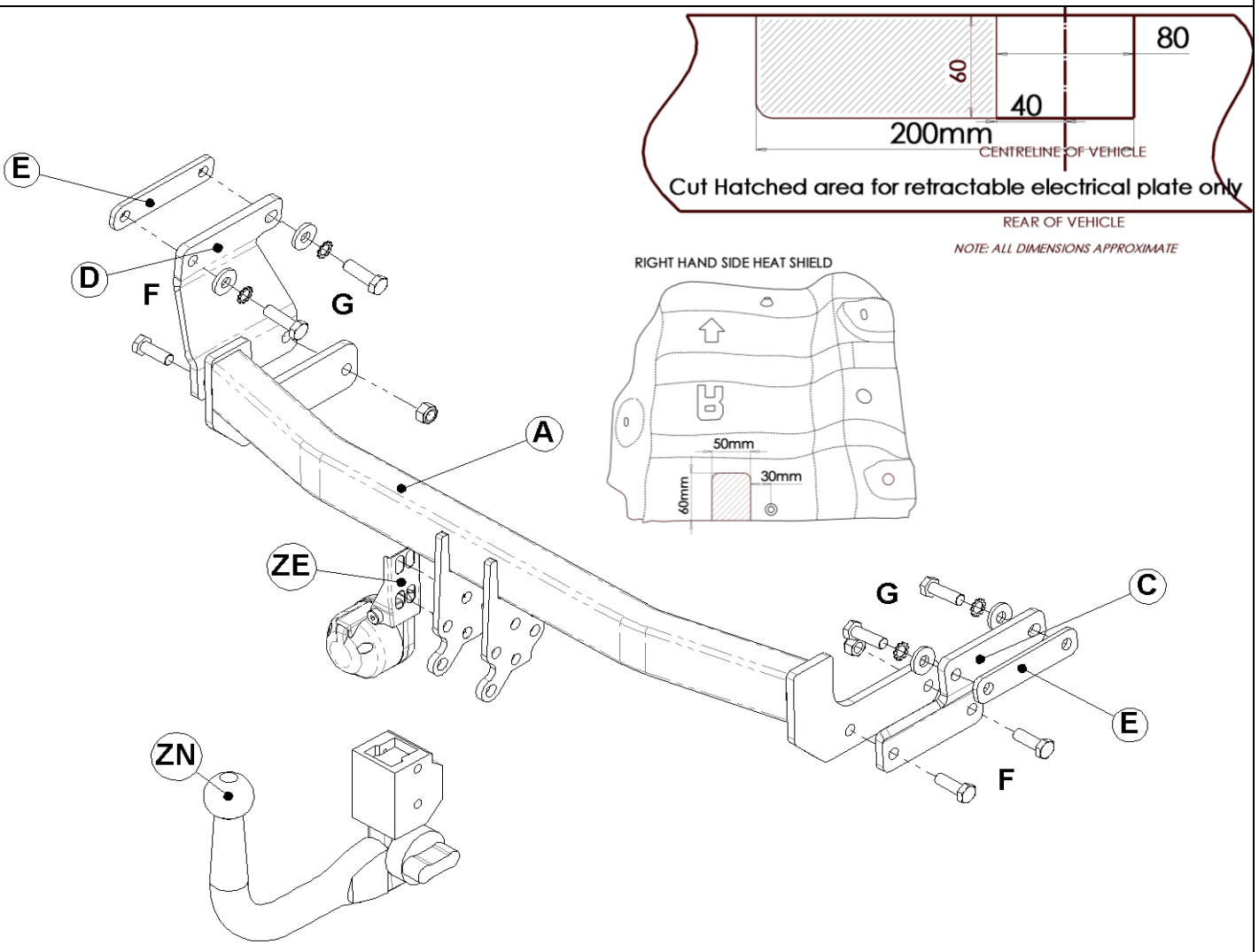

W 0001KA44UU-FIT\$010802220000